



Rear



Optional internal equipment shown



3.6m/11ft 9in 350 LWB - optional equipment shown



4.0m/13ft 350 EF - optional equipment shown

The new Transit CurtainSlider represents the latest in bodywork design, giving unparalleled load access with innovative and practical features to ease everyday operating tasks. Sliding, semi rigid curtains provide a neat, attractive solution for pallet loads used in the Distribution and Just-in-Time industries, where productivity and load turn-around are critical.

One-Stop CurtainSlider

The CurtainSlider provides superb access to the load deck, giving maximum flexibility in loading and unloading from three sides of the load area, whether it be fast access to the load from the sides using Fork Trucks, or load bay access via the rear doors. The sliding design of the curtains ensure the curtains 'pleat' efficiently when opened giving maximum access width to the load area, once unloaded any remaining load can be accessed by pulling the curtain to the other end of the body.

The standard aero-pack significantly reduces drag, improving journey times, fuel economy and driver fatigue. A range of useful optional equipment is available at extra cost to provide greater ease of use and protection, including a bespoke curtain colourway and screen printing service.

Available in 3.6m and 4.0m internal bodylengths with a choice of 115PS, 140PS or 200PS Duratorq TDCi diesel engines the Ford Transit Curtainside provides one of the finest distribution vehicles available.

Features include:

- 18mm resin bonded ply floor
- Translucent GRP Roof
- GRP overcab air dam and side streamers (frozen white only)
- Integral box section aluminium curtain stiffeners
- Roller bearing top runners
- Locking curtains and rear Doors
- 270 rear doors with retainers
- Powder coat aluminium rear door panels (frozen white only)
- Mid blue curtains fitted as standard, all cab colours optional colours available at extra cost

Optional bump strip helps reduce damage from Fork Trucks



Curtain retainers built into curtain lower runner



Lockable rear door handle with top and bottom latch



Telescopic rear door retainers hold doors safely in the 270° position. Brolly handle retainers rotate and stow under the load deck when not in use.



Standard nearside bulkhead mounted grab handle with optional side underrun guard step, tubular stirrup step fitted as standard



Interior 50W Halogen worklamp mounted on a ball and socket joint can be repositioned to suit lighting requirements



Optional flush fitting grab handles



Optional bulkhead load-loc rail and additional lath's, 6 fitted as standard



Flush fitting pull-up load anchorage points, 4 per side mounted discreetly into the curtain lower runner section



3.6m/ 11ft 9in Curtainside 350L

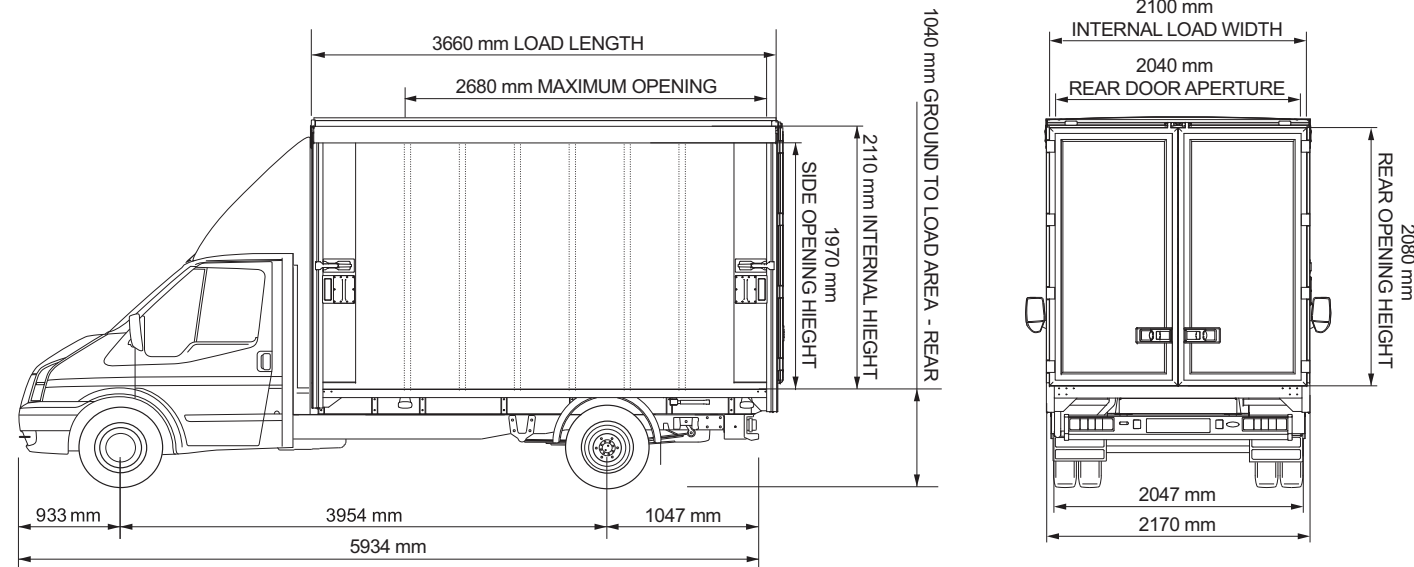

4.0m/ 13ft 1in Curtainside 350EF

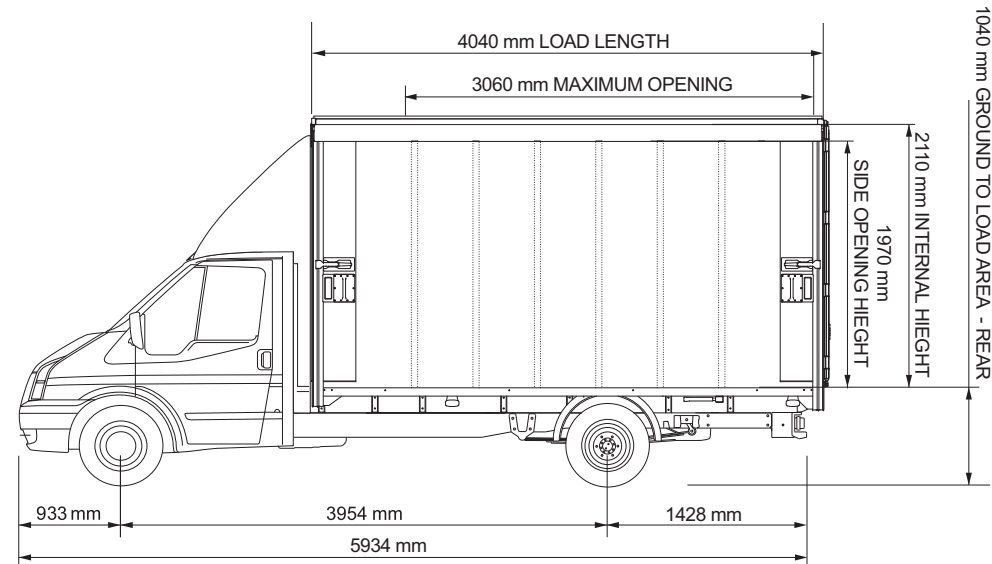

Note: Illustrations above shown optional curtain grab handles. Rear door handles are subject to change, handle position will be changed to below the door.

Weights and loads

| | Rear axle ratio | 350L | 350EF |
|-------------------------------|-----------------|------|-------|
| Plated weights (kg) | | | |
| FAM | | 1750 | 1750 |
| FAM – Optional | | 1850 | 1850 |
| RAM | | 2450 | 2450 |
| GVM | | 3500 | 3500 |
| GTM 115PS (2.4L)* | 4.27 | 6000 | 6000 |
| GTM 140PS (2.4L)* | 4.27 | 6300 | 6300 |
| GTM 200PS (3.2L)* | 4.10 | 6500 | 6500 |
| Payload | | | |
| 4cyl 115/140PS* | | 1090 | 1065 |
| 5 cyl 200PS* | | 1013 | 988 |
| Cubic capacity m ³ | | 15.5 | 17.1 |

*Payloads quoted are gross (full tank of fuel, oil and fluids, no driver) and for minimum specification, optional chassis equipment including 1850Kg front axle and optional body equipment will reduce payload allowance. Subject to manufacturing tolerance. **FAM** = Front axle plated mass. **RAM** = Rear axle plated mass. **GVM** = Gross vehicle mass. **GTM** = Gross train mass.

Specifications

| | Chassis | Cab |
|---|---------|-----|
| Chassis | | |
| Engine availability – Refer to chart (page 54) | | |
| Transmission – 6 speed MT82 | | ● |
| Rear Axle – 115/140 PS – dual rear wheel 4.27 ratio | | ● |
| Rear Axle – 200 PS – dual rear wheel 4.10 ratio | | ● |
| Tyres – 185/75 R16C 104/102 (1750Kg front axle) | | ● |
| Tyres – 195/75 R16C 107/105 (1850Kg Front Axle) | | ○ |
| Suspension – Front, coil spring MacPherson strut | | ● |
| Suspension – Rear: Taper leaf + helper, anti-roll bar | | ● |
| Seating – Driver's seat and dual passenger seat, lap and diagonal seat belts to all seats | | ● |
| Electrical – Battery: 12V 2 x 590CCA (60Ah @ 20 hr rate) batteries, primary battery isolator relay | | ● |
| Cold start (-29°C) includes twin 680 CCA (70Ah @ 20h rate) batteries – recommended if additional electrical equipment fitted. | | ○ |
| Electrical – Alternator: 150 Amp | | ● |
| Colour – Frozen White only | | ● |
| Type – Sliding curtain, dual opening rear doors | | ● |
| Colour – Curtains: Mid blue standard (other colours available). | | ● |
| Doors: Frozen white with natural anodised aluminium framework. | | ● |
| Overcab airdam: Frozen white gel coat GRP | | ● |
| Overcab air dam with cab side streamers (Gel coat Frozen white only) | | ● |

Specifications

| | Chassis | Cab |
|--|---------|-----|
| Curtains - Reinforced PVC with integral vertical box section aluminium stiffeners. Top hung rollers with adjustable end latches to maintain curtain tension. | | ● |
| Bulkhead - Double skinned aluminium with 6 wooden lath's | | ● |
| Understructure – Full-length aluminium longitudinals and crossbearers, steel bulkhead buttress plates | | ● |
| Structure – Extruded anodised aluminium frame | | ● |
| Roof – Translucent GRP with top hat roof bows | | ● |
| Floor – Embossed 18 mm thick phenolic resin full birch plywood | | ● |
| Rear Doors – 270° powder coated aluminium panel doors, internal door locking mechanism, bottom lockable handle. (Powder coat Frozen White only) | | ● |
| Rear Door retainers - Telescopic Broly handle retainers in the 270 open position, stowed under floor when not deployed | | ● |
| Lighting – Internal rotating high mounted 50W halogen spot lamp | | ● |
| Load Lashing – Pull-up load anchorage rings mounted in raves, 4 per side. 2 lashing rings mounted on bulkhead | | ● |
| Curtain stops - Rave mounted pull up & turn lock stops holding curtain open in the forward or rearward positions | | ● |
| Step & Grab handle - Nearside mounted stirrup step with bulkhead mounted grab handle | | ● |
| Body Warranty – 3-year, 100,000 miles | | ● |

● = Standard, ○ = Option, at extra cost. **NOTE: Drawings are representative and may be subject to change. Optional side curtain grab handles shown, rear door handle position changed to below the door in production, fittings and equipment subject to change.**