



GLOSSARY OF TERMS

Plated weight

The maximum weight to which a vehicle or an axle may be loaded, determined either by the design of the components or by legislation. All commercial vehicles must carry a manufacturer's 'plate' showing the vehicle and axle gross 'plated weights'. It is an offence to drive a vehicle in a condition where any of these weights are exceeded.

Kerbweight

The weight of the complete vehicle in standard form, excluding payload and driver but including coolant, oil, 90% full fuel tank and spare wheel where appropriate. Kerbweights quoted in Vauxhall brochures are subject to manufacturing tolerances and to the fitment of optional equipment and accessories. Where load capacity is critical the actual kerbweight should be obtained by weighing the vehicle on a calibrated public weighbridge.

Gross Vehicle Weight (GVW)

The total permissible weight of a vehicle including payload and passengers, as shown on the manufacturer's plate.

Gross Combination Weight (GCW)

The maximum permissible weight of a vehicle, including payload and passengers, combined with the total weight of any trailer it is towing. The maximum GCW weight limit is quoted on the vehicle plate and must not be exceeded.

Payload

The total permissible weight that can be carried without exceeding the vehicle's plated weight. This can be obtained by deducting the kerbweight from the plated Gross Vehicle Weight (GVW).

Please note: the payload figure does not allow for the weight of the driver or any passengers.

Maximum towing weight

The maximum weight of any trailer and its load which may be towed within the limit of the vehicle's plated Gross Combination Weight (GCW). It is based on the ability of the vehicle – at full GCW – to restart on a 12% gradient, which is approximately 1 in 8.3, at sea level. At altitudes above 1500 metres, the engine output may drop with a corresponding reduction in towing capability. It is the operator's responsibility to ensure that the trailer noseweight does not cause the rear axle plated weight of the towing vehicle to be exceeded.

Always fit Vauxhall towing attachments and accessories available from your Vauxhall Commercial Vehicle retailer. They are designed specifically for Vauxhall models and carry a 12-month warranty.



Contents

Corsavan	
- Equipment	S.2
- Technical data	S.4
Astravan	
- Equipment	S.6
- Technical data	S.8
Combo	
- Equipment	S.10
- Technical data	S.12
Customer care	S.14
Glossary of terms	S.16

Corsavan, Astravan and Combo specifications



Every effort has been made to ensure that the contents of this publication were accurate and up-to-date at the time of going to press (April 2006). Vauxhall vehicles are equipped with components manufactured by various General Motors operating units and outside suppliers. The Company reserves the right to alter specifications and withdraw products from sale without notice. Any such alterations will be notified to Vauxhall retailers at the earliest opportunity; please consult your local retailer for the latest information. The specifications detailed within this brochure are not necessarily applicable to alternative models such as Special Editions. Details of any such models will be contained in specific literature or found on the Vauxhall website. Please note that Vauxhall retailers are not the agents of Vauxhall Motors Limited and are not authorised to bind the Company by any specific or implied undertaking or representation. It is advisable to ensure that your motor insurance policy provides adequate cover for additional fitted options and accessories. As part of Vauxhall's policy of environmental care, this brochure is printed on paper manufactured using Elemental Chlorine Free pulps from specially farmed, sustainable timber resources. All rights reserved. No part of this publication may be reproduced in any form or by any means, without the prior written permission of Vauxhall Motors Limited.

Published April 2006 (Graymatter) Vauxhall Motors Limited, Luton LU1 3YT www.vauxhall.co.uk

VM0606222

CORSAVAN EQUIPMENT



Tilttable steering column.



Electrically operated windows.



Driver's seat height adjuster.

Safety

Standard features • Anti-lock Braking System (ABS) with Electronic Brakeforce Distribution (EBD) • Emergency Brake Assist (EBA) • Driver's airbag • Height-adjustable head restraints • Height-adjustable inertia-reel lap and diagonal seatbelts • Pyrotechnic body-lock seatbelt pretensioner system • Driver's seatbelt force limiter • Pedal release system • Anti-submarining ramps in seats • Side-impact protection beams • Laminated windscreen • Fuel tank located ahead of rear axle

Additional feature	1.2i 16v	1.3CDTi 16v
Passenger's airbag	○	○

Facia, instruments and controls

Standard features • Trip odometer • Rev counter • Electronically controlled coolant temperature gauge and fuel gauge with low fuel level warning light • Service-due indicator • 12-volt electrical accessory socket • Digital clock and outside air temperature display • Instrument panel light dimmer • Lidded glovebox • Storage box on driver's side facia

Additional feature	1.2i 16v	1.3CDTi 16v
Tilttable steering column	□	□

Audio

Standard features • CD 30 stereo radio (24 presets)/CD player • Remote display • Balance control • Programmable speed-dependent volume control with traffic programme • Separate bass and treble controls • Fader control • FM and MW reception • Microprocessor-controlled quartz tuning • Manual tuning function • Automatic search tuning • Autostore function • Full RDS EON • Traffic Programme • Four speakers (20 watts per channel) • Flexible roof-mounted aerial

Additional features	1.2i 16v	1.3CDTi 16v
CDC 40 stereo radio (36 presets) with Digital Audio Broadcast (DAB)/integral six-disc CD autochanger/graphic display/steering wheel mounted audio controls/four speakers (35 watts per channel)	○	○
Steering wheel mounted audio controls	○	○

Seating

Standard features • Orleans cloth seat trim • Reclining seats

Additional feature	1.2i 16v	1.3CDTi 16v
Driver's seat height adjuster	○	○

Interior features

Standard features • Twin sunvisors and dipping rear-view mirror • Air blend heater with four-speed fan • Cabin pollen filter and odour-reducing activated charcoal filter • Door armrests • Door pockets • Centre console with drinks holder • Carpeted cabin area

Additional features	1.2i 16v	1.3CDTi 16v
Air-conditioning and air recirculation facility	○	○
Passenger's underseat storage tray	□	□
Driver's sunglasses holder	□	□
Map reading lights	□	□
Cigar lighter	□	□
Front ashtray	□	□

Mechanical

Standard features • Five-speed manual gearbox • Electric speed-sensitive power-assisted steering

Additional feature	1.2i 16v	1.3CDTi 16v
Easytronic five-speed transmission with sequential manual gearshift or automatic mode		○

Security

Standard features • Remote control central deadlocking (doors and tailgate) • Electronic theft protection for audio equipment • Electronic engine deadlock immobiliser • 'Key left in ignition' audible warning • Visible Vehicle Identification Number (VIN) • Steering column lock • Freewheeling door locks

Additional feature	1.2i 16v	1.3CDTi 16v
Remote control ultrasonic security alarm system	○	○

Load area

Features	1.2i 16v	1.3CDTi 16v
Glazed tailgate	●	●
Half-height steel bulkhead	●	●
Loadspace sidewall half-height protection panelling	●	●
Load restraint lashing eyes	●	●
Illuminated load area	●	●
Upper load restraint mesh	○	○
Load area rubber floor mat	○	○

Exterior features

Standard features • Lights-on audible warning • H7 halogen headlights • Electric headlight beam levelling • Two-speed windscreen wipers with variable intermittent wipe and electric screenwash • Body side-protection mouldings • Twin internally adjustable foldable door mirrors (wide-angle on driver's side) • High-level LED centre brake light • Green-tinted glass • Hazard warning lights and side repeat indicators • Rear fog light • Reversing light • Heated rear window • Intermittent rear window wash/wipe • Body-colour bumpers with black protective inserts

Additional features	1.2i 16v	1.3CDTi 16v
Front fog lights	□	□
Electrically operated windows with safety autoreverse and one-touch facility	□	□
Electrically adjustable/heated door mirrors (wide-angle on driver's side)	□	□
Body-colour door mirrors	□	□
Two-coat metallic or pearlescent paint	○	○
Special paint (restrictions apply – please consult your retailer for availability)	○	○

Wheels and tyres

Features	1.2i 16v	1.3CDTi 16v
13-inch steel wheels with 155/80 R 13 tyres	●	
14-inch steel wheels with 175/65 R 14 tyres		●
Full-diameter flush wheel covers	●	●
14-inch alloy wheels (13-inch steel spare) with 175/65 R 14 tyres and lockable centre caps	□	□

Option packs

	1.2i 16v	1.3CDTi 16v
Function pack • Tilttable steering column • Passenger's underseat storage tray • Driver's sunglasses holder • Map reading lights	○	○
Electric pack • Electrically operated windows • Electrically adjustable/heated door mirrors • Body-colour door mirrors	○	○
Exterior pack • 14-inch alloy wheels (13-inch steel spare) with 175/65 R 14 tyres and lockable centre caps • Front fog lights	○	○
Smoker pack • Cigar lighter • Front ashtray	○	○

● = Standard equipment.
○ = Optional at extra cost.
□ = Only available as part of an extra-cost option pack.

CORSAVAN TECHNICAL DATA



Payload
425kg-465kg

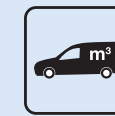

Loadspace
1.06cu.m



Load length
1245mm

Engines

	1.2i 16v Twinport ECOTEC-4	1.3CDTi 16v ECOTEC-4
Fuel type	Petrol	Diesel
Capacity	1229cc	1248cc
Maximum power	80PS (59kW) @ 5600rpm	70PS (51kW) @ 4000rpm
Maximum torque	110Nm (81 lb.ft.) @ 4000rpm	170Nm (125 lb.ft.) @ 1750-2500rpm
Compression ratio	10.5:1	18.0:1
Emission compliance	Euro 4	
Layout	4 cylinders, 4 valves per cylinder, double overhead camshafts	
Induction system	Multi-point sequential electronic fuel injection	Turbocharger and common rail fuel injection
Throttle control	Electronic cable-free 'drive by wire'	
Service interval	20,000 miles or one year (whichever occurs sooner)	

Transmission ratios

Manual 5-speed	Clutch diameter	Gear ratios (mph/1000rpm)						Reverse	Final drive ratio
		1	2	3	4	5			
1.2i 16v	190mm	3.73:1 (4.5)	2.14:1 (7.8)	1.41:1 (11.8)	1.12:1 (14.9)	0.89:1 (18.8)	3.31:1	3.94:1	
1.3CDTi 16v	216mm	3.73:1 (5.0)	1.96:1 (9.5)	1.31:1 (14.2)	0.95:1 (19.6)	0.76:1 (24.6)	3.31:1	3.55:1	
Easytronic 5-speed									
1.3CDTi 16v	216mm	3.73:1 (5.0)	1.96:1 (9.5)	1.31:1 (14.2)	0.95:1 (19.6)	0.76:1 (24.6)	3.31:1	3.55:1	

Fuel economy

1.3CDTi 16v manual – 65.1 mpg (4.4 litres/100km) obtained during road testing with a 330kg payload by *Commercial Fleet World* magazine – February 2004.

Important: Figures quoted relate to the particular vehicle tested by an independent organisation. Variations in equipment, payload, driving style, road and traffic conditions, vehicle mileage and standard of maintenance may also affect fuel consumption, therefore the test results do not express or imply any guarantee of fuel consumption attainable.

Transmissions

- Front-wheel drive
 - Hydraulically actuated, asbestos-free, self-adjusting single-plate clutch
 - Five-speed manual gearbox – standard on all models
 - Five-speed Easytronic transmission – available at extra cost on 1.3CDTi 16v models
- Choose the optional Easytronic transmission and you'll get a five-speed manual gearbox with a fully automatic mode. In manual mode, you simply push the lever forward or back to shift gears up or down. The facia display tells you what gear you're in – 1 to 5, N for Neutral or A for Auto. Switch to fully automatic mode and it has many of the features of a regular automatic including a kickdown function. There's no clutch pedal so you can drive it on an automatic-only driving licence.

Steering

- Rack and pinion
- Speed-sensitive electric power-assisted steering
- Turning circle:
 - Kerb-to-kerb – 10.05m (33.0ft.)
 - Wall-to-wall – 10.45m (34.3ft.)
- Turns lock-to-lock: 2.9

Suspension

Front: Independent. MacPherson struts with gas-pressure damper cartridge and coil springs. Anti-roll bar.
Rear: Compound crank with progressive-rate double conical mini-block springs, gas-pressure dampers and steel control arms.

Brakes

- Anti-lock Braking System (ABS) with Electronic Brakeforce Distribution (EBD)
 - Emergency Brake Assist (EBA)
 - Dual circuit, diagonally split servo-assisted system
 - Asbestos-free brake linings
 - Plastic-coated brake pipes
 - Low brake fluid warning light
- Front ventilated disc brakes:**
 1.2i 16v – 240mm.
 1.3CDTi 16v – 260mm.
- Rear self-adjusting drum brakes:**
 200mm diameter.

Body

- Extensive anti-corrosion protection
- Aerodynamic drag co-efficient: Cd 0.32
- Front and rear safety deformation zones
- Reinforced passenger safety cell
- Side-impact protection beams
- Flush-fitting front and rear screens
- Burst-proof door locks
- Front and rear towing eyes

Anti-corrosion protection

- Galvanised bodyshell
- Anti-corrosion wax pumped into sills and other underbody cavities
- All weld seams and joints sealed with special compound
- Hem flanges of bonnet, doors and tailgate bonded and sealed
- Abrasion-resistant coatings applied to wheel arches and other underbody areas
- Plastic front wheel arch liners
- Bodyshell dip-primered electrostatically
- Paint finish applied electrostatically

Electrics

Alternator: 70A (1.3CDTi 16v models fitted with optional air-conditioning – 100A).
Maintenance-free battery:
 1.2i 16v – 36Ah.
 1.2i 16v with air-conditioning option – 55Ah.
 1.3CDTi 16v – 60Ah.

Fuel tank capacity

45 litres (9.9 gallons).

Dimensions millimetres (inches)

All heights are shown unladen.

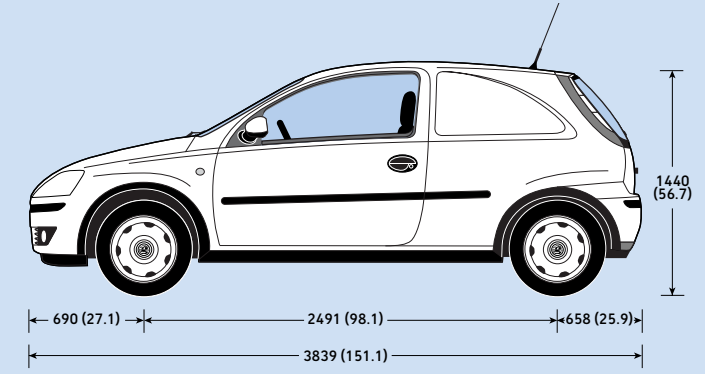
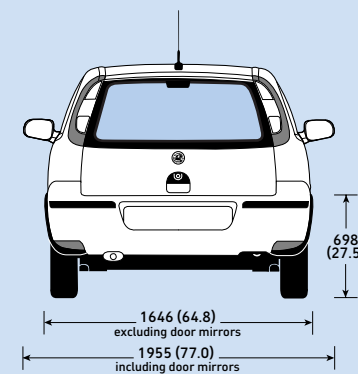

Loadspace dimensions

	mm (inches)
Max. tailgate aperture height	627 (24.7)
Max. tailgate aperture width	1004 (39.5)
Loading height (unladen)	698 (27.5)

Loadspace volume

VDA method	cu.m (cu.ft.)
All models	1.06 (37.4)

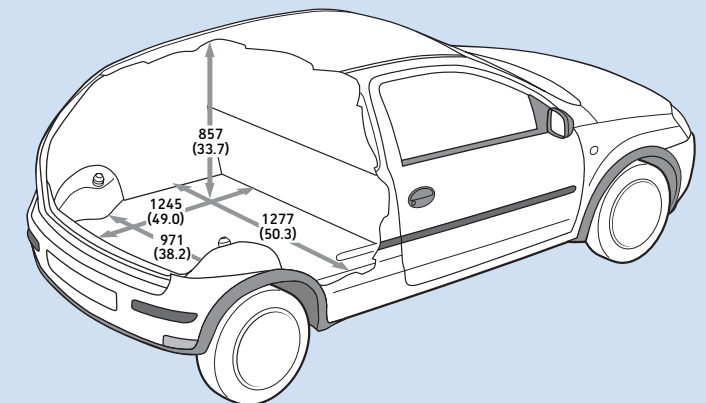

Weights and towing data

Model	UK plated weights and kerbweights kg						Payload kg	Towing weights Trailer with brakes (without brakes) kg	Plated Gross Combination Weights (GCW) kg
	Front axle		Rear axle		Total				
	Plated	Kerb	Plated	Kerb	GVW	Kerb			
1.2i 16v	745	587	705	378	1390	965	425	805 (450)	2235
1.2i 16v (a/c)	770	615	705	375	1420	990	430	780 (450)	2235
1.3CDTi 16v	840	678	705	377	1520	1055	465	1000 (450)	2520
1.3CDTi 16v (a/c)	860	706	705	374	1545	1080	465	1000 (450)	2545

a/c = Air-conditioning.

Note: Kerbweights for standard vehicles include coolant, oil, 90% full fuel tank and spare wheel. They will vary according to the vehicle specification (including options and accessories) with a corresponding variation in payload. **Payload** figures do not allow for the weight of the driver, or any passengers, which should therefore be deducted from the figures shown. **Gross plated weights** (including axle weights) quoted on the vehicle plate must never be exceeded. **Roof load** should not exceed 100kg including the weight of the roof rack/carrier.

Vauxhall Assistance and warranties*

Every Corsavan comes with:

- A one-year unlimited mileage manufacturer's warranty
- Second and third year no-fee customer option warranty up to 60,000 miles (from date of first registration)
- Vauxhall Assistance for 12 months from first registration (see page S.14)
- Six-year body panel anti-perforation warranty

* = Warranty is only available on vehicles sourced from Vauxhall Motors Ltd. Terms and conditions apply – please see your Vauxhall Commercial Vehicle retailer for details.

Insurance group

All models – Group 1E.

As recommended by the Association of British Insurers.

ASTRAVAN EQUIPMENT



Air-conditioning.



CD 413 stereo radio/CD player.



Service-due indicator.

Safety

Standard features • Anti-lock Braking System (ABS) with Electronic Brakeforce Distribution (EBD) • Driver's airbag • Height-adjustable head restraints • Height-adjustable inertia-reel lap and diagonal seatbelts • Pyrotechnic body-lock seatbelt pretensioner system • Seatbelt force limiters • Pedal release system • Anti-submarining ramps in seats • Side-impact protection beams • Fuel tank located ahead of rear axle • Laminated windscreen

Additional feature	Envoy	LS	Sportive
Passenger's airbag	○	○	○

Facia, instruments and controls

Standard features • Trip odometer • Rev counter • Multi-function display showing time, date and outside air temperature (with ice warning function) • Electronically controlled coolant temperature gauge and fuel gauge with low fuel level warning light • Service-due indicator • Cigar lighter/12-volt electrical accessory socket • Instrument panel light dimmer • Illuminated lidded glovebox with pen holder • Lidded storage compartment on driver's side facia

Additional feature	Envoy	LS	Sportive
Steering column adjustable for reach and rake	□	●	

Audio

Standard features • CD 413 stereo radio/CD player • Balance control • FM, MW and LW reception • Microprocessor-controlled quartz tuning • Up and down manual tuning function • Automatic search tuning • Autostore function • Full RDS EON • Traffic programme • Four speakers (20 watts per channel) • Flexible roof-mounted aerial

Seating

Standard feature • Reclining seats adjustable for reach and rake

Additional features	Envoy	LS	Sportive
Orleans cloth seat trim	●	●	N/C
Vinyl seat trim	○ ¹		
Sports seats with lumbar adjustment in Texas cloth seat trim	○ ²	○ ²	● ³
Driver's seat height adjuster	□	●	● ³
Fold-forward passenger's seat back	● ¹	● ²	N/C ³

Interior features

Standard features • Fade up/fade down interior courtesy light • Twin sunvisors and dipping rear-view mirror • Door armrests • Door pockets • Four drinks holders (two in door pockets, two in glovebox lid) • Carpeted cabin area • Air blend heater with four-speed fan • Cabin pollen filter • Air recirculation system with activation light • Front ashtray

Additional feature	Envoy	LS	Sportive
Air-conditioning	○	○	●

Mechanical

Standard features • Five-speed manual gearbox • Electro-hydraulic power-assisted steering

Security

Standard features • Remote control central deadlocking (doors, tailgate and fuel flap) • Electronic theft protection for audio equipment • Electronic engine deadlock immobiliser • 'Key left in ignition' audible warning • Visible Vehicle Identification Number (VIN) • Steering column lock • Freewheeling door locks

Additional feature	Envoy	LS	Sportive
Remote control ultrasonic security alarm system with tilt sensor	○	○	○

Load area

Features	Envoy	LS	Sportive
Glazed tailgate	●	●	●
Half-height steel bulkhead	●	●	●
Loadspace sidewall half-height protection panelling	●	●	●
Load restraint lashing eyes	●	●	●
Illuminated load area	●	●	●
Upper load restraint mesh	○	●	○

Exterior features

Standard features • Lights-on audible warning • H7 halogen headlights • Electric headlight beam levelling • Two-speed windscreen wipers with variable intermittent wipe and electric screenwash • Body-colour front bumper • Body side-protection mouldings • Twin internally adjustable body-colour door mirrors (wide-angle on driver's side) with two-way folding facility • High-level LED centre brake light • Heated rear window with automatic timed cut-off • Intermittent rear window wash/wipe • Green-tinted glass • Twin reversing lights • Twin rear fog lights

Additional features	Envoy	LS	Sportive
Front fog lights	□	□	●
Electrically operated windows with safety autoreverse and one-touch facility	○	○	●
Electrically adjustable/heated door mirrors	○	○	○
Roof rails ⁴		●	●
Two-coat metallic or pearlescent paint	○	○	N/C
Special paint (restrictions apply – please consult your retailer for availability)	○	○	

Wheels and tyres

Standard feature • 15-inch steel wheels with 195/60 R 15 tyres

Additional features	Envoy	LS	Sportive
15-inch alloy wheels (steel spare) with 195/60 R 15 tyres and locking wheel bolts	□	□	●
Full-diameter flush covers	●	●	

Option packs

	Envoy	LS	Sportive
Styling pack • 15-inch alloy wheels (steel spare) with 195/60 R 15 tyres and locking wheel bolts • Front fog lights	○	○	●
Comfort pack • Steering column adjustable for reach and rake • Driver's seat height adjuster	○	●	

● = Standard equipment.
○ = Optional at extra cost.
N/C = No-cost option.
□ = Only available as part of an extra-cost option pack.

1 = Vinyl seat trim not available in conjunction with fold-forward passenger's seat back or sports seats.
2 = Sports seats delete fold-forward passenger's seat back.

3 = Sports seats in Texas cloth and driver's seat height adjuster are deleted when fold-forward passenger's seat back is specified.
4 = Must be used with a separate base carrier (available as a Vauxhall accessory) if loads are to be carried on the roof.

ASTRAVAN TECHNICAL DATA



Payload
600kg-610kg

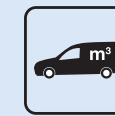

Load volume
1.60cu.m



Load length
1701mm

Engines

	1.6i 16v Twinport ECOTEC-4	1.7CDTi 16v ECOTEC-4
Fuel type	Petrol	Diesel
Capacity	1598cc	1686cc
Maximum power	105PS (77kW) @ 6000rpm	80PS (59kW) @ 4400rpm
Maximum torque	150Nm (111 lb.ft.) @ 3900rpm	170Nm (125 lb.ft.) @ 1800-2800rpm
Compression ratio	10.5:1	18.4:1
Emission compliance	Euro 4	
Layout	4 cylinders, 4 valves per cylinder, double overhead camshafts	
Induction system	Multi-point sequential electronic fuel injection	Turbocharger and common rail fuel injection
Throttle control	Electronic cable-free 'drive by wire'	
Service interval	20,000 miles or one year (whichever occurs sooner)	

Transmission ratios

Manual 5-speed	Clutch diameter	Gear ratios (mph/1000rpm)						Reverse	Final drive ratio
		1	2	3	4	5			
1.6i 16v	200mm	3.73:1 (4.8)	2.14:1 (8.3)	1.41:1 (12.6)	1.12:1 (15.8)	0.89:1 (19.9)	3.31:1	3.94:1	
1.7CDTi 16v	205mm	3.73:1 (5.3)	1.96:1 (10.0)	1.31:1 (15.0)	0.95:1 (20.7)	0.76:1 (25.9)	3.31:1	3.55:1	

Fuel economy

1.7CDTi 16v LS – 54mpg (5.2 litres/100km) unladen obtained during road testing by *What Van?* magazine – August 2004.

Important: Figures quoted relate to the particular vehicle tested by an independent organisation. Variations in equipment, payload, driving style, road and traffic conditions, vehicle mileage and standard of maintenance may also affect fuel consumption; therefore the test results do not express or imply any guarantee of fuel consumption attainable.

Fuel tank capacity

52 litres (11.4 gallons).

Transmission

- Front-wheel drive
- Five-speed manual gearbox
- Hydraulically actuated, asbestos-free, self-adjusting single-plate clutch

Steering

- Electro-hydraulic power-assisted rack and pinion system
- Turning circle: Kerb-to-kerb – 10.55m (34.6ft.) Wall-to-wall – 11.00m (36.1ft.)
- Turns lock-to-lock: 3.1

Suspension

Front: Independent. Lightweight MacPherson struts with coil springs and gas-pressure dampers. Anti-roll bar.

Rear: Torsion tube with compound links, progressive-rate double conical mini-block springs and gas-pressure dampers.

Electrics

Alternator: All models – 70A.

Maintenance-free battery:

1.6i 16v – 44Ah.

1.6i 16v with air-conditioning option – 55Ah.

1.7CDTi 16v – 70Ah.

Brakes

- Anti-lock Braking System (ABS) with Electronic Brakeforce Distribution (EBD)
- Dual circuit, diagonally split servo-assisted system
- Asbestos-free brake linings
- Front brake pad wear audible warning
- Plastic-coated brake pipes

Front ventilated disc brakes:

256mm diameter.

Rear self-adjusting drum brakes:

230mm diameter.

Body

- Extensive anti-corrosion protection
- Aerodynamic drag co-efficient: Cd 0.314
- Front and rear safety deformation zones
- Reinforced passenger safety cell
- Side-impact protection beams
- Flush-fitting front and rear screens
- Flush-mounted door handles
- Recessed windscreen wipers
- Burst-proof door locks

Anti-corrosion protection

- Galvanised bodyshell
- Anti-corrosion wax pumped into sills and other underbody cavities
- All weld seams and joints sealed with special compound
- Hem flanges of bonnet, doors and tailgate bonded and sealed
- Abrasion-resistant coating applied to wheel arches and other underbody areas
- Plastic front wheel arch liners
- Bodyshell dip-primed electrostatically
- Paint finish applied electrostatically

Dimensions millimetres (inches)

All heights are shown unladen.

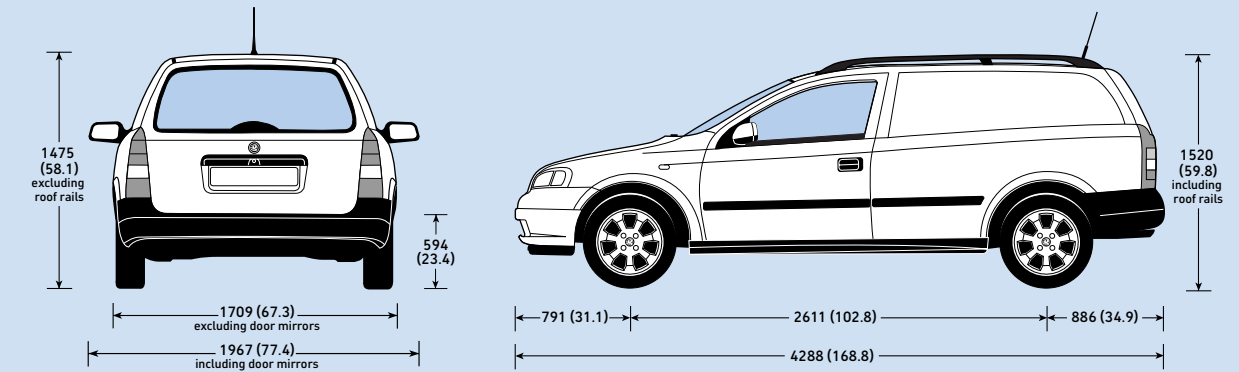

Loadspace dimensions

	mm (inches)
Max. tailgate aperture height	788 (31.0)
Max. tailgate aperture width	1112 (43.8)
Loading height (unladen)	594 (23.4)

Loadspace volume

VDA method	cu.m (cu.ft.)
All models	1.60 (56.5)

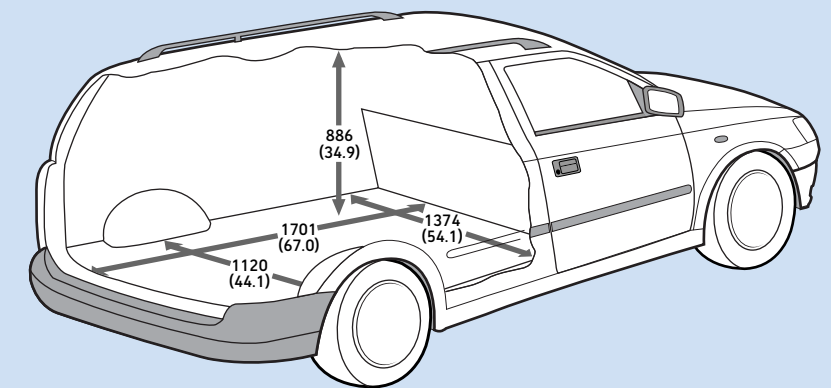

Weights and towing data

Model	UK plated weights and kerbweights kg						Payload kg	Towing weights Trailer with brakes (without brakes) kg	Plated Gross Combination Weights (GCW) kg
	Front axle		Rear axle		Total				
	Plated	Kerb	Plated	Kerb	GVW	Kerb			
1.6i 16v	845	680	885	430	1710	1110	600	1100 (570)	2810
1.6i 16v (a/c)	865	700	885	430	1730	1130	600	1050 (570)	2780
1.7CDTi 16v	935	760	885	425	1795	1185	610	1100 (600)	2895
1.7CDTi 16v (a/c)	955	780	885	425	1815	1205	610	1100 (600)	2915
1.7CDTi 16v Sportive	955	780	885	425	1815	1205	610	1100 (600)	2915

a/c = Air-conditioning.

Note: Kerbweights for standard vehicles include coolant, oil, 90% full fuel tank and spare wheel. They will vary according to the vehicle specification (including options and accessories) with a corresponding variation in payload. **Payload** figures do not allow for the weight of the driver, or any passengers, which should therefore be deducted from the figures shown. **Gross plated weights** (including axle weights) quoted on the vehicle plate must never be exceeded. **Roof load** should not exceed 100kg including the weight of the roof rack/carrier.

Vauxhall Assistance and warranties*

Every Astravan comes with:

- A one-year unlimited mileage manufacturer's warranty
- Second and third year no-fee customer option warranty up to 60,000 miles (from date of first registration)
- Vauxhall Assistance for 12 months from first registration (see page S.14)
- Six-year body panel anti-perforation warranty

* = Warranty is only available on vehicles sourced from Vauxhall Motors Ltd. Terms and conditions apply – please see your Vauxhall Commercial Vehicle retailer for details.

Insurance group

All models – Group 5A.

As recommended by the Association of British Insurers.

COMBO EQUIPMENT



Remote control ultrasonic security alarm system.



CD 30 stereo radio/CD player.



Electrically heated front seats and Smoker pack.

Safety

Standard features	<ul style="list-style-type: none"> • Anti-lock Braking System (ABS) with Electronic Brakeforce Distribution (EBD) • Emergency Brake Assist (EBA) • Driver's airbag • Height-adjustable head restraints • Height-adjustable inertia-reel lap and diagonal front seatbelts • Pyrotechnic body-lock front seatbelt pretensioner system • Front seatbelt force limiters • Pedal release system • Anti-submerging ramps in seats • Side-impact protection beams • Laminated windscreen • Fuel tank located ahead of rear axle 	
Additional features	Combo	Crew van
Front passenger's airbag	○	●
Three inertia-reel lap and diagonal rear seatbelts		●

Facia, instruments and controls

Standard features	<ul style="list-style-type: none"> • Trip odometer • Rev counter • Electronically controlled coolant temperature gauge and fuel gauge with low fuel level warning light • Service-due indicator • 12-volt electrical accessory socket • Digital clock and outside air temperature display • Tilttable steering column • Instrument panel light dimmer • Lidded glovebox • Storage compartment on driver's side facia 	
--------------------------	--	--

Audio and communications

Standard features	<ul style="list-style-type: none"> • CD 30 stereo radio (24 presets)/CD player • Remote display • Balance control • Programmable speed-dependent volume control • Separate bass and treble controls • Fader control • FM and MW reception • Microprocessor-controlled quartz tuning • Manual tuning function • Automatic search tuning • Autostore function • Full RDS EON • Traffic programme • Four speakers (20 watts per channel) • Flexible roof-mounted aerial 	
Additional features	Combo	Crew van
CD 70 stereo radio (24 presets)/CD with MP3 capability/CD-ROM-driven satellite navigation system/Traffic Message Channel (TMC) ¹ /graphic display/steering wheel mounted audio controls/four speakers (20 watts per channel)	○	○
Steering wheel mounted audio controls	○	○
Factory-fit telephone pre-wiring	○	○

Seating

Standard features	<ul style="list-style-type: none"> • Orleans cloth seat trim • Reclining front seats 	
Additional features	Combo	Crew van
Vinyl seat trim	○ ²	
Driver's seat height adjuster ³	○	○
Fold-flat front passenger's seat (not rake-adjustable) ⁴	○	○
Rear seat with fold-flat facility and 60/40 split seat back		●
Electrically heated front seats ⁴	□	□

Interior features

Standard features	<ul style="list-style-type: none"> • Fade up/fade down interior courtesy light • Twin sunvisors and dipping rear-view mirror • Air blend heater with four-speed fan • Cabin pollen filter and odour-reducing activated charcoal filter • Overhead storage shelf • Front door armrests • Front door pockets • Centre console with drinks holder • Carpeted cabin area 	
Additional features	Combo	Crew van
Air-conditioning and air recirculation facility	○	○
Front passenger's underseat storage tray	□	□
Front map reading lights	□	□
Cloth front door trim inserts		●
Carpeted rear passengers' floor		●
Cigar lighter	□	□
Front ashtray	□	□

Security

Standard features	<ul style="list-style-type: none"> • Remote control central deadlocking (doors) • Electronic theft protection for audio equipment • Electronic engine deadlock immobiliser • 'Key left in ignition' audible warning • Visible Vehicle Identification Number (VIN) • Steering column lock • Freewheeling door locks 	
Additional feature	Combo	Crew van
Remote control ultrasonic security alarm system ³	○ ⁵	○

Mechanical

Standard features	<ul style="list-style-type: none"> • Five-speed manual gearbox • Electric power-assisted steering 	
Additional features	Combo	Crew van
Up-rated alternator (standard with air-conditioning)	○	○
Underbody protection and increased ground clearance for bad road usage	○	○

Load area

Standard features	<ul style="list-style-type: none"> • Glazed rear doors • Loadspace sidewall half-height protection panelling • Load restraint lashing eyes • Illuminated load area 	
Additional features	Combo	Crew van
Half-height steel bulkhead	●	
Unglazed rear doors ⁶	N/C ⁷	N/C ⁷
Tailgate with heated window and wash/wipe facility	○	○
Nearside sliding side-access door	○	
Offside and nearside sliding side-access doors	○	●
FlexCargo fold-flat front passenger's seat ⁴ (not rake-adjustable) and hinged, movable bulkhead	○ ⁸	
Fold-flat front passenger's seat (not rake-adjustable)	○ ⁸	○
Upper load restraint mesh	○ ⁸	
Rear internal working lights (2 x 20W)	○	
Load area rubber floor mat (reduced length on crew van models)	○	●
Load area headlining and storage net pockets		●
Rear load cover		●

Exterior features

Standard features	<ul style="list-style-type: none"> • Lights-on audible warning • H7 halogen headlights • Electric headlight beam levelling • Two-speed windscreen wipers with variable intermittent wipe and electric screenwash • Body side-protection mouldings • Twin internally adjustable and foldable door mirrors (wide-angle on driver's side) • Green-tinted glass • Reversing light • Rear fog light 	
Additional features	Combo	Crew van
Front fog lights	□	□
High-level LED brake lights ⁷	●	●
Electrically operated front windows with safety autoreverse and one-touch facility	○	○
Electrically adjustable/heated body-colour door mirrors	○	○
Heated rear windows	□	
Intermittent rear window wash/wipers	□	
Two-coat metallic or pearlescent paint	○	○
Two-coat solid black paint	○	○
Special paint (restrictions apply – please consult your retailer for availability)	○	○

Wheels and tyres

Features	Combo	Crew van
14-inch steel wheels with 175/70 R 14 tyres (1700 models exc. 1.7CDTi 16v) and centre covers	●	
15-inch steel wheels with 185/60 R 15 tyres (2000/1.7CDTi 16v models) and full-diameter flush covers	●	●

Option packs

Function pack A	Combo	Crew van
• Front passenger's underseat storage tray		
• Driver's seat height adjuster		
• Remote control ultrasonic security alarm system	○	
• Heated rear windows		
• Intermittent rear window wash/wipers		
• Front map reading lights		
Function pack B		
• Front passenger's underseat storage tray		
• Driver's seat height adjuster		
• Remote control ultrasonic security alarm system	○	○
• Unglazed rear doors ⁷		
• Front map reading lights		
Winter pack		
• Electrically heated front seats ⁴	○	○
• Front fog lights		
Smoker pack		
• Cigar lighter	○	○
• Front ashtray		

● = Standard equipment.
○ = Optional at extra cost.
N/C = No-cost option.
□ = Only available as part of an extra-cost option pack.

1 = The Traffic Message Channel (TMC) is a specific application of RDS used for broadcasting real-time traffic information.
2 = Vinyl seat trim not available when fold-flat front passenger's seat or FlexCargo options are specified.
3 = Driver's seat height adjuster and remote control ultrasonic security alarm system are also available as part of optional Function pack(s).
4 = Electrically heated front seats are not available in conjunction with FlexCargo or fold-flat front passenger's seat options.

5 = Remote control ultrasonic security alarm system only available in conjunction with optional unglazed rear doors or Function pack(s).
6 = Unglazed rear doors also available as part of optional Function pack B.
7 = High-level LED brake lights are not available when unglazed rear doors are specified.
8 = Upper load restraint mesh is not available in conjunction with FlexCargo or fold-flat front passenger's seat options.

COMBO TECHNICAL DATA



Payload
588kg-803kg

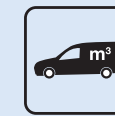

Loadspace
2.7-3.2cu.m

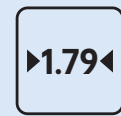

Load length
1787mm-
2700mm

Engines

	1.4i 16v Twinport ECOTEC-4	1.3CDTi 16v ECOTEC-4	1.7CDTi 16v ECOTEC-4
Fuel type	Petrol	Diesel	Diesel
Capacity	1364cc	1248cc	1686cc
Maximum power	90PS (66kW) @ 5600rpm	70PS (51kW) @ 4000rpm	100PS (74kW) @ 4400rpm
Maximum torque	125Nm (92 lb.ft.) @ 4000rpm	170Nm (125 lb.ft.) @ 1750-2500rpm	240Nm (177 lb.ft.) @ 2300rpm
Compression ratio	10.5:1	18.0:1	18.4:1
Emission compliance	Euro 4	Euro 3	Euro 4
Layout	4 cylinders, 4 valves per cylinder, double overhead camshafts		
Induction system	Multi-point sequential electronic fuel injection	Turbocharger and common rail fuel injection	
Throttle control	Electronic cable-free 'drive by wire'		
Service interval	20,000 miles or one year (whichever occurs sooner)		

Transmission ratios

Manual 5-speed	Clutch diameter	Gear ratios (mph/1000rpm)						Final drive ratio
		1	2	3	4	5	Reverse	
1700 1.4i 16v	200mm	3.73:1 (4.3)	1.96:1 (8.4)	1.31:1 (12.5)	0.95:1 (17.2)	0.76:1 (21.5)	3.31:1	4.18:1
2000 1.4i 16v	200mm	3.73:1 (4.4)	1.96:1 (8.4)	1.31:1 (12.5)	0.95:1 (17.3)	0.76:1 (21.6)	3.31:1	4.18:1
1700 1.3CDTi 16v	216mm	3.73:1 (4.6)	1.96:1 (8.9)	1.31:1 (13.3)	0.95:1 (18.2)	0.76:1 (22.8)	3.31:1	3.94:1
2000 1.3CDTi 16v	216mm	3.73:1 (4.7)	1.96:1 (8.9)	1.31:1 (13.3)	0.95:1 (18.3)	0.76:1 (22.9)	3.31:1	3.94:1
1700/2000 1.7CDTi 16v	228mm	3.58:1 (5.0)	1.89:1 (9.4)	1.19:1 (15.0)	0.85:1 (21.0)	0.69:1 (25.9)	3.31:1	3.84:1

Fuel economy

1.7CDTi 16v 2000 – 54mpg (5.2 litres/100km) unladen, 52.2mpg (5.4 litres/100km) laden obtained during road testing by *Commercial Motor* magazine – March 2006.

1.3CDTi 16v 2000 – 51mpg (5.6 litres/100km) unladen obtained during road testing by *What Van?* magazine – February 2005.

Important: Figures quoted relate to the particular vehicle tested by an independent organisation. Variations in equipment, payload, driving style, road and traffic conditions, vehicle mileage and standard of maintenance may also affect fuel consumption; therefore the test results do not express or imply any guarantee of fuel consumption attainable.

Fuel tank capacity

52 litres (11.4 gallons).

Transmission

- Front-wheel drive
- Five-speed manual gearbox
- Hydraulically actuated, asbestos-free, self-adjusting single-plate clutch

Steering

- Electric power-assisted rack and pinion system
- Energy-absorbing steering column
- Turning circle:
 - Kerb-to-kerb – 10.82m (35.5ft.)
 - Wall-to-wall – 11.25m (36.9ft.)
- Turns lock-to-lock: 2.9

Suspension

Front: Independent. MacPherson struts with coil springs, gas-pressure dampers. Anti-roll bar.
Rear: Torsion tube with compound links, progressive-rate double conical mini-block springs and gas pressure dampers.

Electrics

Alternator:

1.4i 16v/1.3CDTi 16v/1.7CDTi 16v – 70A.
1.4i 16v with optional air-conditioning – 120A.
1.3CDTi 16v/1.7CDTi 16v with optional air-conditioning – 100A.

Maintenance-free battery:

1.4i 16v – 44Ah (55Ah with optional air-conditioning).
1.3CDTi 16v/1.7CDTi 16v – 60Ah (70Ah with optional air-conditioning).

Brakes

- Anti-lock Braking System (ABS) with Electronic Brakeforce Distribution (EBD)
- Emergency Brake Assist (EBA)
- Dual circuit, diagonally split servo-assisted system
- Asbestos-free brake linings
- Plastic-coated brake pipes

Front ventilated disc brakes:

260mm diameter.

Rear disc brakes:

264mm diameter (2000 and 1.7CDTi 16v models).

Rear self-adjusting drum brakes:

230mm diameter (1700 exc. 1.7CDTi 16v models).

Body

- Extensive anti-corrosion protection
- Aerodynamic drag co-efficient: Cd 0.346
- Front and rear safety deformation zones
- Reinforced passenger safety cell
- Side-impact protection beams
- Flush-fitting front windscreen
- Flush-fitting door handles
- Burst-proof door locks
- Front and rear towing eyes
- Rear doors with 90° and 180° opening

Anti-corrosion protection

- Galvanised bodyshell
- Anti-corrosion wax pumped into sills and other underbody cavities
- All weld seams and joints sealed with special compound
- Hem flanges of bonnet and all doors bonded and sealed
- Anti-corrosion primers used extensively on bonnet, doors, wings and other panels
- Abrasion-resistant coating applied to wheel arches and other underbody areas
- Plastic front wheel arch liners
- Bodyshell dip-primed electrostatically
- Paint finish applied electrostatically

Vauxhall Assistance and warranties*

Every Combo comes with:

- A one-year unlimited mileage manufacturer's warranty
- Second and third year no-fee customer option warranty up to 60,000 miles (from date of first registration)
- Vauxhall Assistance for 12 months from first registration (see page S.14)
- Six-year body panel anti-perforation warranty

* = Warranty is only available on vehicles sourced from Vauxhall Motors Ltd. Terms and conditions apply – please see your Vauxhall Commercial Vehicle retailer for details.

Insurance group

All models – Group 1E.

As recommended by the Association of British Insurers.

Dimensions millimetres (inches)

All heights are shown unladen.

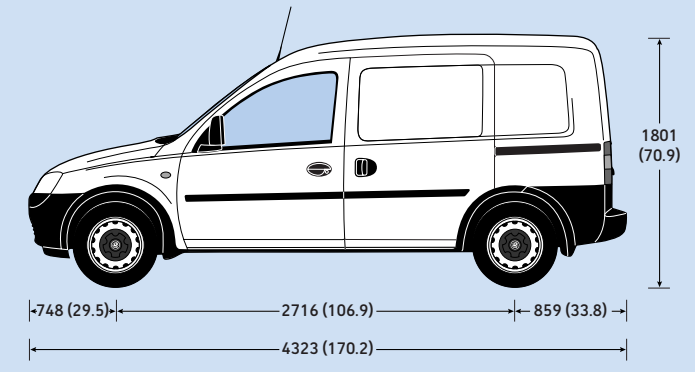
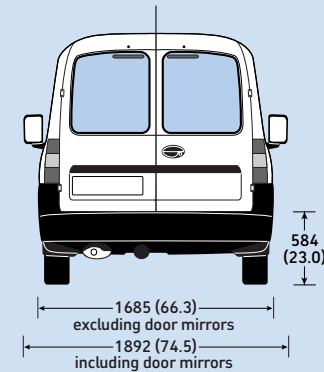

Loadspace dimensions

Max. load length	mm (inches)
Standard vehicle (A)	1787 (70.3)
With optional FlexCargo	2700 (106.3)
Crew van with seats up	980 (38.6)
Crew van with seats down	1980 (78.0)
Max. load width	
At widest point (B)	1348 (53.1)
Between wheel arches (C)	1107 (43.6)
Max. load height	
Standard vehicle (D)	1175 (46.3)
Crew van – minimum	1140 (44.9)
Crew van – maximum	1170 (46.1)
Rear and side load door(s)	
Loading height (unladen)	584 (23.0)
Rear door aperture height	1139 (44.8)
Rear door aperture width	1238 (48.7)
Side door aperture height	913 (35.9)
Side door aperture width	620 (24.4)

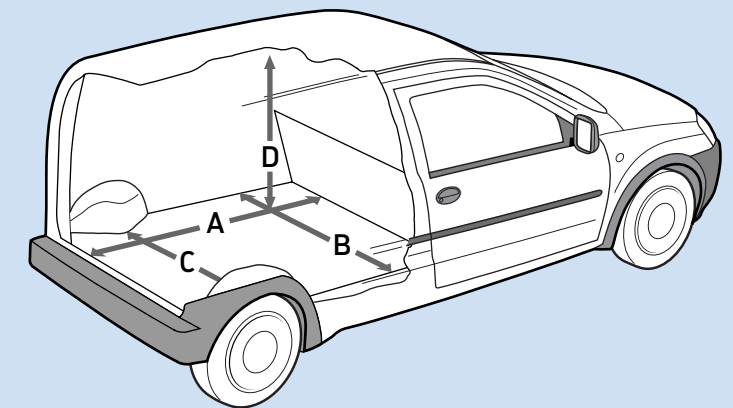

Loadspace volumes

SAE method	cu.m (cu.ft.)	VDA method	cu.m (cu.ft.)
Without optional FlexCargo	2.76 (97.5)	Without optional FlexCargo	2.39 (84.4)
With optional FlexCargo	3.20 (113.0)	With optional FlexCargo	2.88 (101.7)
Crew van with seats down	2.70 (95.3)	Crew van with seats down	2.32 (81.9)

Weights and towing data

Model	UK plated weights and kerbweights kg						Payload kg	Towing weights Trailer with brakes (without brakes) kg	Plated Gross Combination Weights (GCW) kg
	Front axle Plated	Rear axle Kerb	Rear axle Plated	Rear axle Kerb	Total GVW	Total Kerb			
1700 1.4i 16v	780	627	960	495	1710	1122	588	1000 (450)	2710
1700 1.4i 16v (a/c)	810	657	960	495	1740	1152	588	1000 (450)	2740
2000 1.4i 16v	815	627	1110	495	1925	1122	803	1000 (450)	2825
2000 1.4i 16v (a/c)	815	657	1110	495	1925	1152	773	1000 (450)	2825
1700 1.3CDTi 16v	865	713	960	497	1805	1210	595	1000 (450)	2815
1700 1.3CDTi 16v (a/c)	895	743	960	497	1835	1240	595	1000 (450)	2815
2000 1.3CDTi 16v	910	713	1110	497	1995	1210	785	1000 (450)	2815
2000 1.3CDTi 16v (a/c)	910	743	1110	497	1995	1240	755	1000 (450)	2815
2000 1.3CDTi 16v crew van	910	723	1110	564	1995	1287	708	1000 (450)	2815
2000 1.3CDTi 16v crew van (a/c)	910	753	1110	564	1995	1317	678	1000 (450)	2815
1700 1.7CDTi 16v	900	757	960	495	1840	1252	588	1000 (450)	2815
1700 1.7CDTi 16v (a/c)	945	787	960	495	1870	1282	588	1000 (450)	2815
2000 1.7CDTi 16v	930	757	1110	495	1995	1252	743	1000 (450)	2815
2000 1.7CDTi 16v (a/c)	945	787	1110	495	1995	1282	713	1000 (450)	2815
2000 1.7CDTi 16v crew van	910	767	1110	562	1995	1329	666	1000 (450)	2815
2000 1.7CDTi 16v crew van (a/c)	940	797	1110	562	1995	1359	636	1000 (450)	2815

a/c = Air-conditioning.

Note: Kerbweights for standard vehicles include coolant, oil, 90% full fuel tank and spare wheel where appropriate. They will vary according to the vehicle specification (including options and accessories) with a corresponding variation in payload. **Payload** figures do not allow for the weight of the driver, or any passengers, which should therefore be deducted from the figures shown. **Gross plated weights** (including axle weights) quoted on the vehicle plate must never be exceeded. **Roof load** should not exceed 100kg including the weight of the roof rack/carrier.



There are more important things to life than worrying about how to finance and service your commercial vehicle, where to go in the event of an accident and how we go about meeting the transport challenges of the future. So when you choose Vauxhall, you can rely on us to safeguard both you and the environment around you, leaving you free to concentrate on the more important business of enjoying your commercial vehicle!

Customer Care Commitment

For added peace of mind, Vauxhall has an innovative Customer Care Commitment* package that offers the following:

- A one-year unlimited mileage manufacturer's warranty
- Second and third year no-fee customer option warranty up to 60,000 miles on Corsavan, Astravan and Combo and 100,000 miles on Vivaro base and Movano base vehicles from date of first registration
- Vauxhall Assistance for 12 months (36 months for Movano) from first registration (conditions may apply to minibus models)
- Six years body panel anti-perforation warranty

* = Warranty is only on vehicles sourced from Vauxhall Motors Ltd. Terms and conditions apply – please see your Vauxhall Commercial Vehicle retailer for details.

Vauxhall Assistance**

Vauxhall Assistance is operated by the AA and is provided automatically with every new Vauxhall Commercial Vehicle for 12 months (36 months on Movano) from first registration and covers everything from accidents, mechanical breakdown and flat tyres to illness while driving. With Vauxhall Assistance help is literally just a free† phone call away, 24 hours a day, 365 days a year!

Benefits include:

- Full rescue service including roadside assistance
- Recovery – if a problem cannot be solved at the roadside, or if someone is taken ill while driving, the driver, vehicle and all passengers will be transported to the nearest Vauxhall retailer or to any single UK destination
- 'At home' service – help will be sent if there is a vehicle problem at the driver's home

- Accident assistance – if your vehicle is immobilised by an accident, both the vehicle and occupants will be recovered to your choice of destination (Vauxhall recommends a Vauxhall Approved Accident Repair Centre, where appropriate)
- Vehicle theft – Vauxhall Assistance will help to keep you mobile in the unlikely event of your vehicle being stolen

** = Conditions may apply to minibus models. Please consult your Vauxhall Commercial Vehicle retailer for details.

† = Mobile phone users will be charged at their standard tariff.

Protecting the environment

Our products are increasingly winning environmental awards, both through the use of more recycled materials and by becoming cleaner and more efficient. For information on Vauxhall's efforts to achieve an environmentally sustainable future, including information on Design for Recycling, take-back of End-of-Life Vehicles (ELVs), and the recycling of ELVs, see www.vauxhall.co.uk/recycling.

Specialist Mobility advice

Motability accredited Vauxhall retailers can provide special mobility help and advice. For full details contact your local Motability accredited Vauxhall retailer or **Freefone 0800 731 5267**.

Fleet Customer Services

Our dedicated support services for fleet managers includes factory demonstrators and information on whole life costs, company vehicle taxation and finance. For further information please call **0870 010 0651**.

Business Lease

Business Lease from GMAC is a lease financing programme offering highly competitive terms on all Vauxhall Commercial Vehicles up to 12 months old. It offers all the versatility of a purchase-based finance plan but makes the most efficient use of current tax and cash-flow benefits to VAT-registered business users. Business Lease is also highly flexible, offering terms of between 12 and 48 months with a variable deposit (subject to a minimum of three months' rental) and a choice of payment profiles. Ask your retailer for full details, or for a written quotation on the Vauxhall Commercial Vehicle of your choice, please contact GMAC, Wesley House, 19 Chapel Street, Luton LU1 2SY. Security may be required, subject to status. Applicants must be aged 18 or over.

Servicing and maintenance

The best way to maximise the performance and reliability of your Vauxhall Commercial Vehicle is to have all routine servicing and maintenance carried out at a Vauxhall Commercial Vehicle retailer. There are around 200 light commercial vehicle and 150 heavy commercial vehicle retailers nationwide.

Sureguard protection

Particularly suitable for drivers covering higher mileages, Sureguard provides additional cover against mechanical and electrical failures above and beyond Vauxhall's Customer Care Commitment.

- Extends Vauxhall Assistance for the full duration of your Sureguard cover
- Can be purchased when you buy your new vehicle, building the cost into the overall finance agreement

Speak to your retailer or call **0870 752 7020** for more information.

Useful Contacts:

- Vauxhall Rental 0870 442 1567
- Fleet support 0870 010 0651
- Military and Diplomatic Sales 0870 442 1580
- Vauxhall Accident Support 0800 010 304
- Sureguard extended warranty 0870 752 7020
- Vauxhall Leasing 0870 737 2557
- Vauxhall Mobility 0800 731 5267



Vauxhall Leasing

As Vauxhall's own contract hire and fleet management operation, Vauxhall Leasing provides a one-stop-shop for competitive car and commercial vehicle leasing solutions – for business users and private individuals. Working with the Vauxhall retailer network, we combine the support of a national contract with the convenience of a local contact. For further information, please see your local Vauxhall Commercial Vehicle retailer or call us on **0870 737 2557**.

Alternatively, you can visit our website at www.vauxhall-leasing.co.uk

In the event of an accident...

Free to all Vauxhall drivers, Vauxhall Accident Support can help keep you mobile following an accident, with prompt recovery to a Vauxhall Approved Accident Repair Centre. For details, Freefone **0800 010 304**.



Anti-perforation warranty

Your new Vauxhall also comes with a body panel anti-perforation warranty for a period of at least six years from the date of first registration.

For more information...

For a brochure on any Vauxhall model (up to a maximum of three per caller) or location of your nearest Vauxhall retailer please **Lo-call 0845 600 1500**. Alternatively, details can be found on our website: www.vauxhall.co.uk

Lo-call 0845 600 1500
www.vauxhall.co.uk

Carry this card

Save up to £1000*
on a new Vauxhall
Commercial Vehicle

Apply for The GM Platinum Card today

- ✚ 100 Rebate Points when you use your GM Card for the first time
- ✚ Redeem 500 Rebate Points as high street vouchers if registered as a company sale
- ✚ 0% p. a. on purchases and balance transfers fixed for the first five months from account opening
- ✚ Applies to all retail Vauxhall Commercial Vehicles

✚ Typical **14.9% APR** variable

Call **0845 746 2777** and quote **REF:AGM2** or apply online at www.gmcard.co.uk/brochure



The GM Platinum Card is issued by HFC Bank Limited and is available to persons aged 18 years or over and resident in the UK (or 21 and over in the Channel Islands) and is subject to status and conditions. Written quotations are available upon request from The GM Platinum Card, PO Box 3615, Birmingham B3 2RJ. The typical APR quoted is the rate for new customers. *Rebate Points are earned on purchases using The GM Platinum Card. Rebate Points are not earned on Balance Transfers or Cash Advances. You earn money off a new Vauxhall/Saab by accumulating Rebate Points under the Rebate Points Programme. Vauxhall Motors Ltd is solely responsible for the operation of the Rebate Points Programme, which is subject to the Rebate Points Programme Rules. You can redeem up to 2500 Rebate Points and unlimited Partner Points subject to the Model Line Maximum which will vary in amount in relation to different Vauxhall/Saab vehicle model lines. Rebate Points and unlimited Partner Points are redeemable as discounts on a new Vauxhall/Saab vehicle and must be redeemed four years from the issue date. Rebate Points may not be redeemed by Motability Contract Hire customers. The GM Card is a trading name and style of both HFC Bank Limited and Vauxhall Motors Ltd. HFC Bank registered in England No. 1117305. Registered Office: North Street, Winkfield, Windsor, Berkshire SL4 4TD is authorised and regulated by the Financial Services Authority. **Member HSBC Group**. HFC Bank Limited is not a member of the same group of companies as Vauxhall Motors Ltd, Saab GB Limited or GMAC. Vauxhall Motors Ltd, Registered Office: Griffin House, Osborne Road, Luton, Bedfordshire LU1 3YT. Registered in England number 135767.